

CS255: Winter 2014

# PRPs and PRFs

1. Abstract ciphers: PRPs and PRFs,
2. Security models for encryption,
3. Analysis of CBC and counter mode

# PRPs and PRFs

- Pseudo Random Function (**PRF**) defined over  $(K, X, Y)$ :

$$F: K \times X \rightarrow Y$$

such that exists “efficient” algorithm to evaluate  $F(k, x)$

---

- Pseudo Random Permutation (**PRP**) defined over  $(K, X)$ :

$$E: K \times X \rightarrow X$$

such that:

1. Exists “efficient” algorithm to evaluate  $E(k, x)$
2. The function  $E(k, \cdot)$  is one-to-one
3. Exists “efficient” inversion algorithm  $D(k, x)$

# Running example

- Example PRPs: 3DES, AES, ...

AES-128:  $K \times X \rightarrow X$  where  $K = X = \{0,1\}^{128}$

DES:  $K \times X \rightarrow X$  where  $X = \{0,1\}^{64}$ ,  $K = \{0,1\}^{56}$

3DES:  $K \times X \rightarrow X$  where  $X = \{0,1\}^{64}$ ,  $K = \{0,1\}^{168}$

- Functionally, any PRP is also a PRF.
  - A PRP is a PRF where  $X=Y$  and is efficiently invertible.

# Secure PRFs

- Let  $F: K \times X \rightarrow Y$  be a PRF

$$\left\{ \begin{array}{l} \text{Funs}[X,Y]: \text{ the set of all functions from } X \text{ to } Y \\ S_F = \{ F(k,\cdot) \text{ s.t. } k \in K \} \subseteq \text{Funs}[X,Y] \end{array} \right.$$

- Intuition: a PRF is **secure** if  
a random function in  $\text{Funs}[X,Y]$  is indistinguishable from  
a random function in  $S_F$

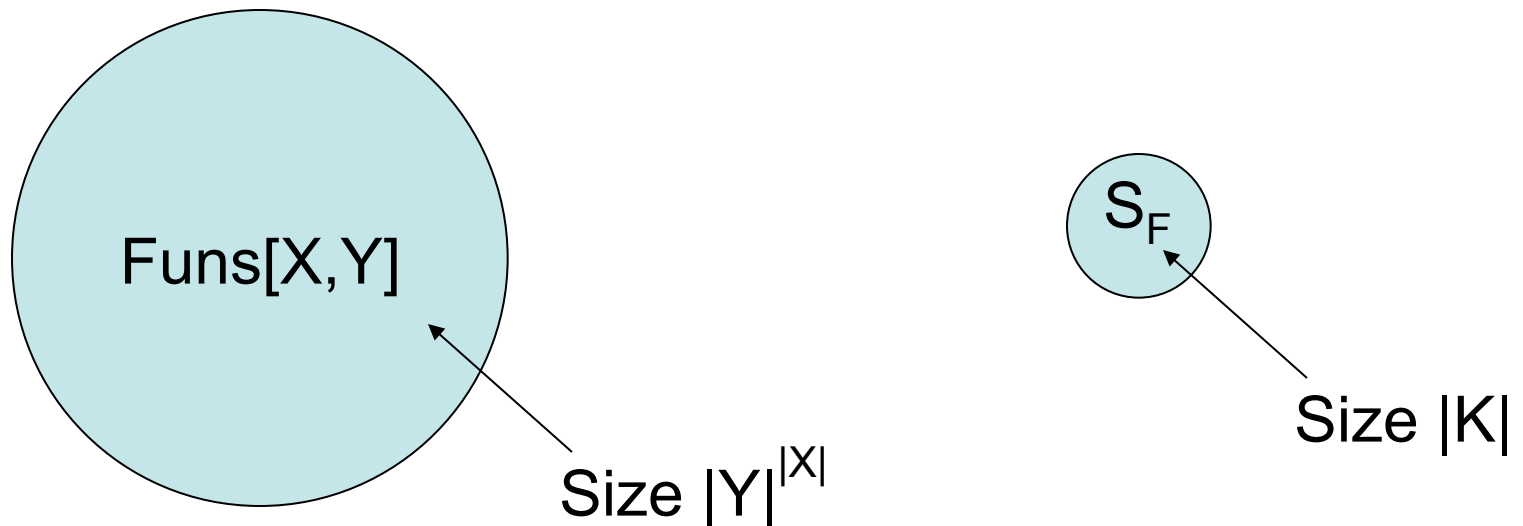

# Secure PRFs

- Let  $F: K \times X \rightarrow Y$  be a PRF

$$\left\{ \begin{array}{l} \text{Funs}[X,Y]: \text{ the set of all functions from } X \text{ to } Y \\ S_F = \{ F(k,\cdot) \text{ s.t. } k \in K \} \subseteq \text{Funs}[X,Y] \end{array} \right.$$

- Intuition: a PRF is **secure** if a random function in  $\text{Funs}[X,Y]$  is indistinguishable from a random function in  $S_F$

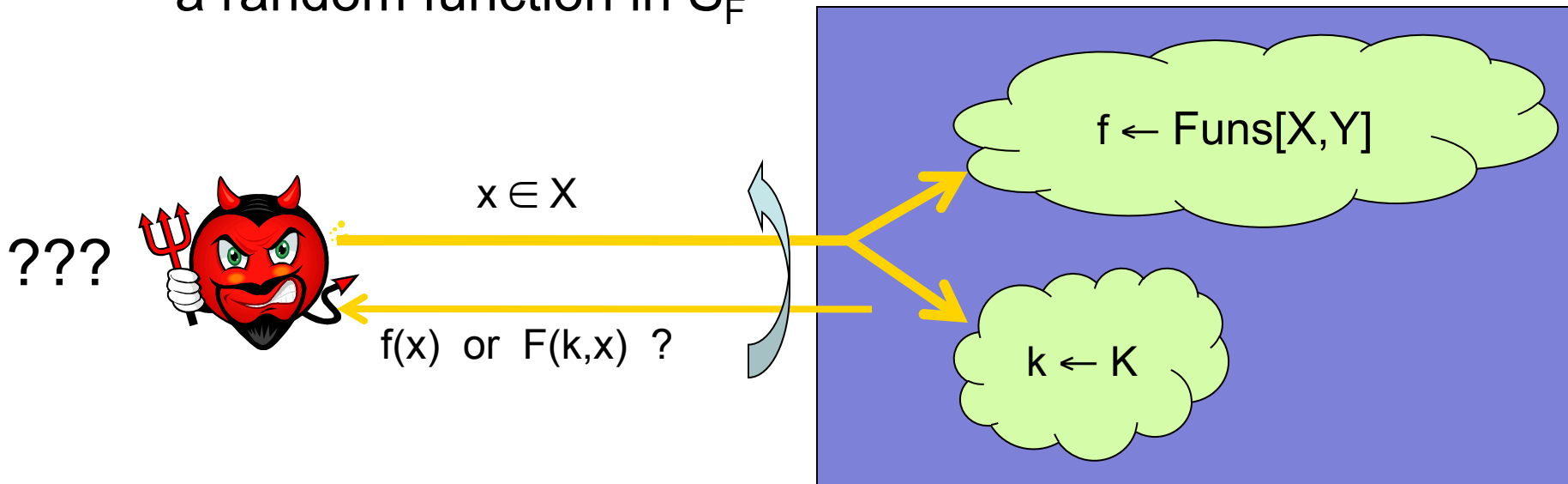

# Secure PRF: definition

- For  $b=0,1$  define experiment  $\text{EXP}(b)$  as:

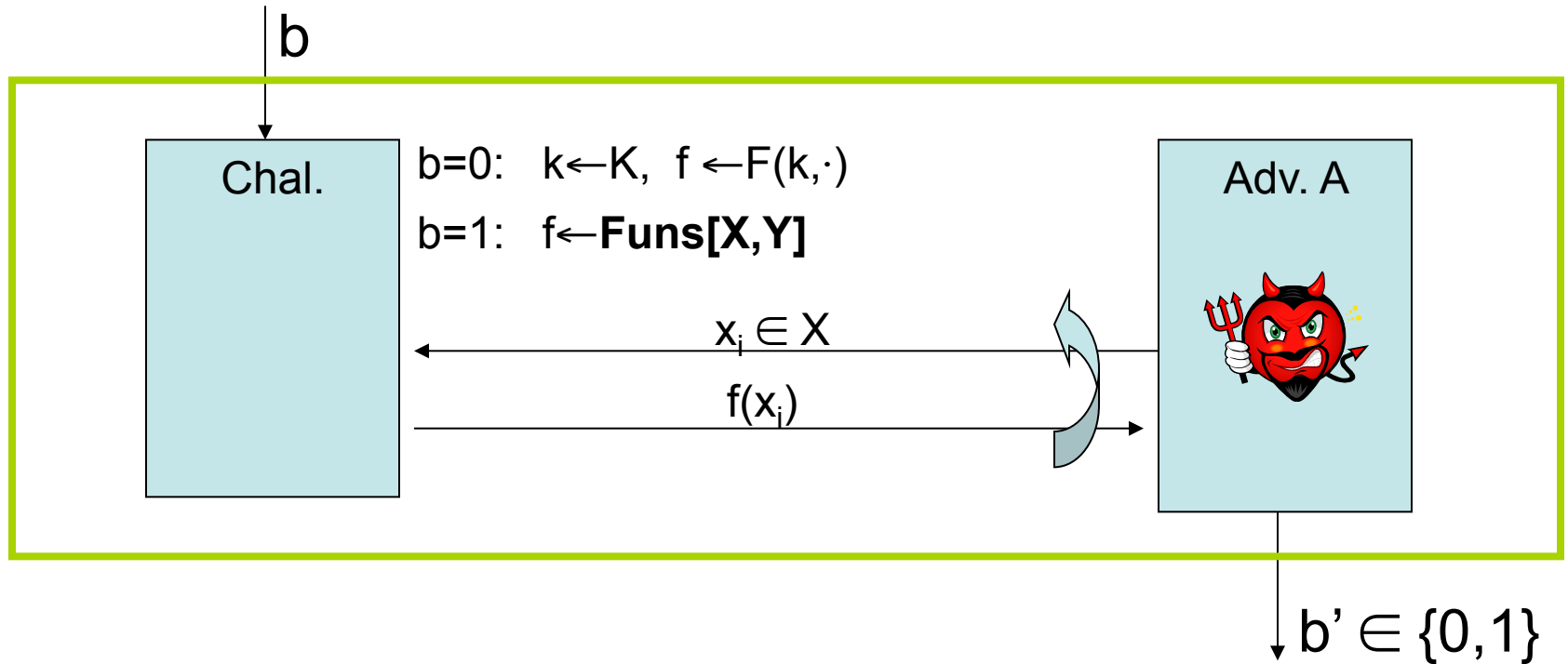

- Def:  $F$  is a secure PRF if for all “efficient”  $A$ :

$$\text{PRF Adv}[A, F] = \left| \Pr[\text{EXP}(0)=1] - \Pr[\text{EXP}(1)=1] \right|$$

is “negligible.”

# Secure PRP

- For  $b=0,1$  define experiment  $\text{EXP}(b)$  as:

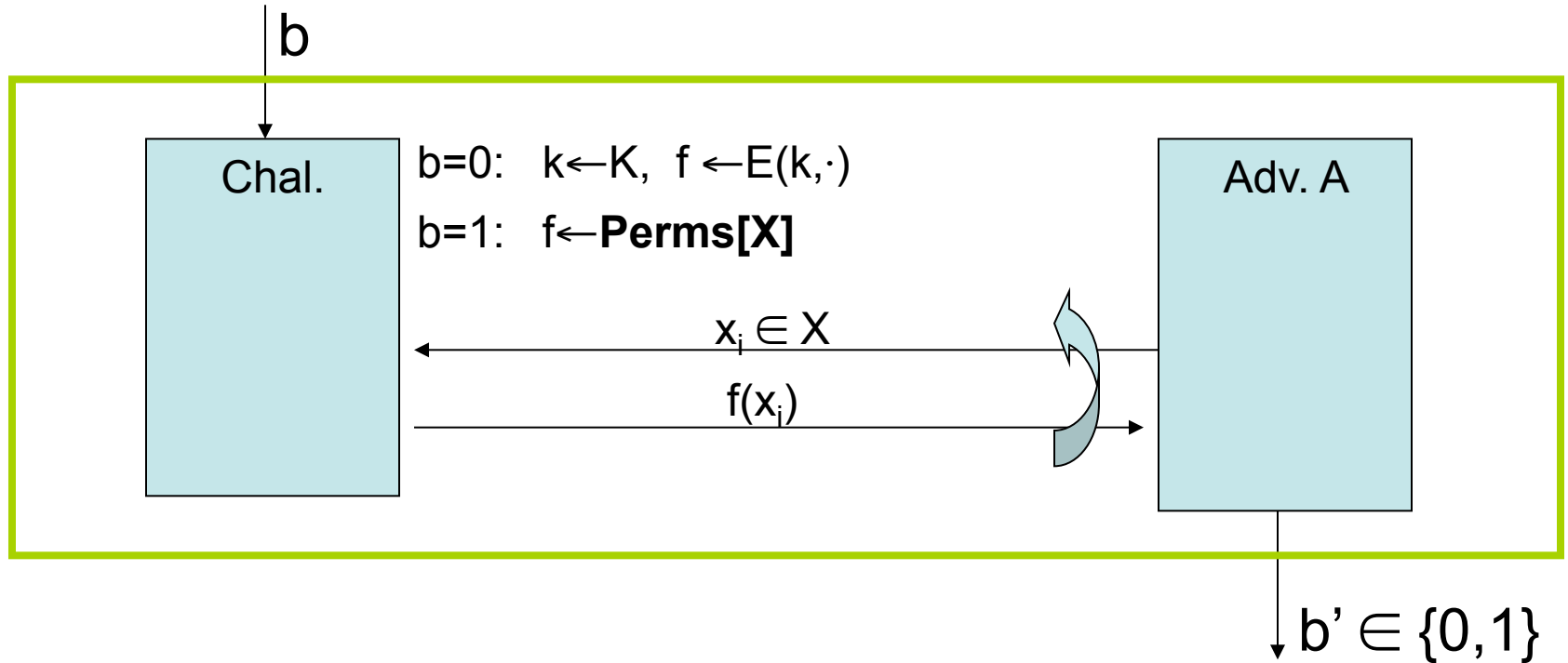

- Def:  $E$  is a secure PRP if for all “efficient”  $A$ :

$$\text{PRP Adv}[A, E] = \left| \Pr[\text{EXP}(0)=1] - \Pr[\text{EXP}(1)=1] \right|$$

is “negligible.”

# Example secure PRPs

- Example secure PRPs: 3DES, AES, ...

AES:  $K \times X \rightarrow X$  where  $K = X = \{0,1\}^{128}$

- AES PRP Assumption (example):

All  $2^{80}$ -time algs  $A$  have  $\text{PRP Adv}[A, \text{AES}] < 2^{-40}$



# PRF Switching Lemma

- Any secure PRP is also a secure PRF.
- Lemma: Let  $E$  be a PRP over  $(K, X)$   
Then for any  $q$ -query adversary  $A$ :

$$\left| \text{PRF Adv}[A, E] - \text{PRP Adv}[A, E] \right| < q^2 / 2|X|$$

---

$\Rightarrow$  Suppose  $|X|$  is large so that  $q^2 / 2|X|$  is “negligible”

Then

$$\text{PRP Adv}[A, E] \text{ “negligible”} \Rightarrow \text{PRF Adv}[A, E] \text{ “negligible”}$$

# Using PRPs and PRFs

- Goal: build “secure” encryption from a PRP.
- Security is always defined using two parameters:

1. What “**power**” does adversary have?

examples:

- Adv sees only one ciphertext (one-time key)
- Adv sees many PT/CT pairs (many-time key, CPA)

2. What “**goal**” is adversary trying to achieve?

examples:

- Fully decrypt a challenge ciphertext.
- Learn info about PT from CT (semantic security)

# Incorrect use of a PRP

Electronic Code Book (ECB):

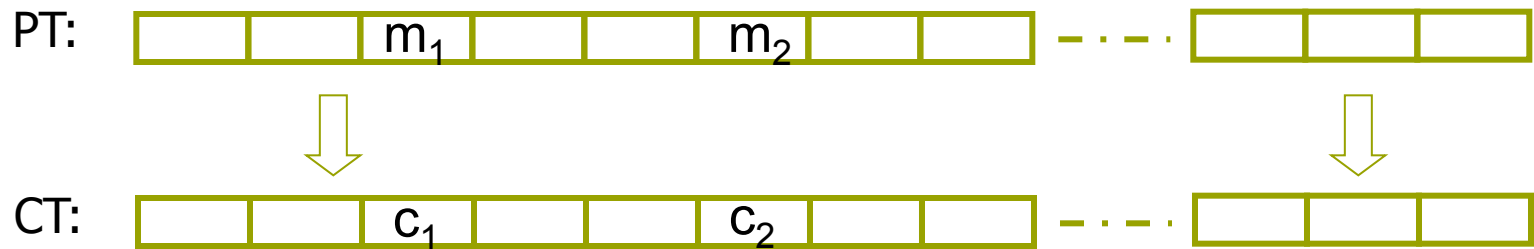

• Problem:

– if  $m_1 = m_2$  then  $c_1 = c_2$

# In pictures

An example plaintext



Encrypted with AES in ECB mode

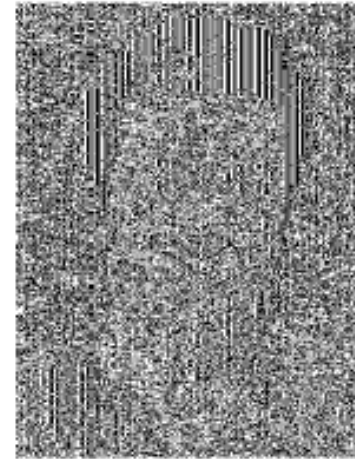

(courtesy B. Preneel)

# Modes of Operation for One-time Use Key

Example application:

Encrypted email.    New key for every message.

# Semantic Security for one-time key

- $E = (E, D)$  a cipher defined over  $(K, M, C)$
- For  $b=0,1$  define  $EXP(b)$  as:

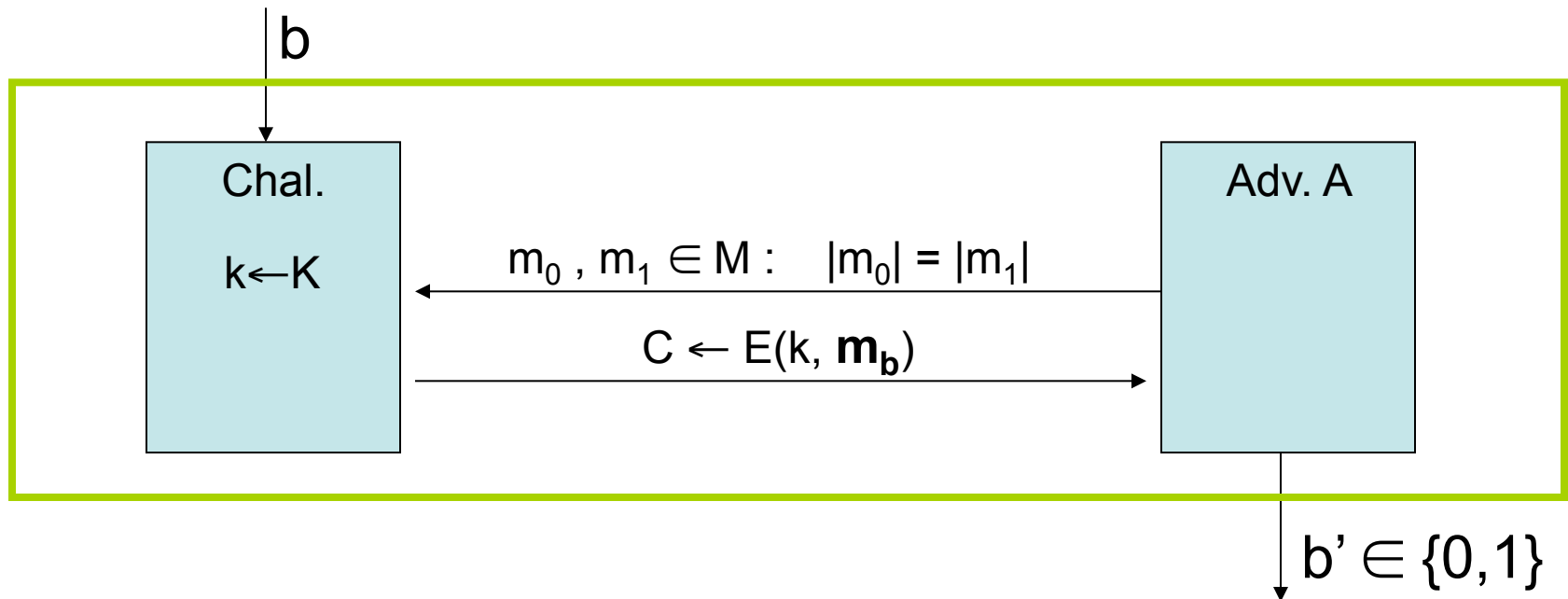

- Def:  $E$  is sem. sec. for one-time key if for all “efficient”  $A$ :

$$SS \text{ Adv}[A, E] = \left| \Pr[EXP(0)=1] - \Pr[EXP(1)=1] \right|$$

is “negligible.”

# Semantic security (cont.)

- Sem. Sec.  $\Rightarrow$  no “efficient” adversary learns info about PT from a **single** CT.
- Example: suppose efficient A can deduce LSB of PT from CT. Then  $E = (E, D)$  is not semantically secure.

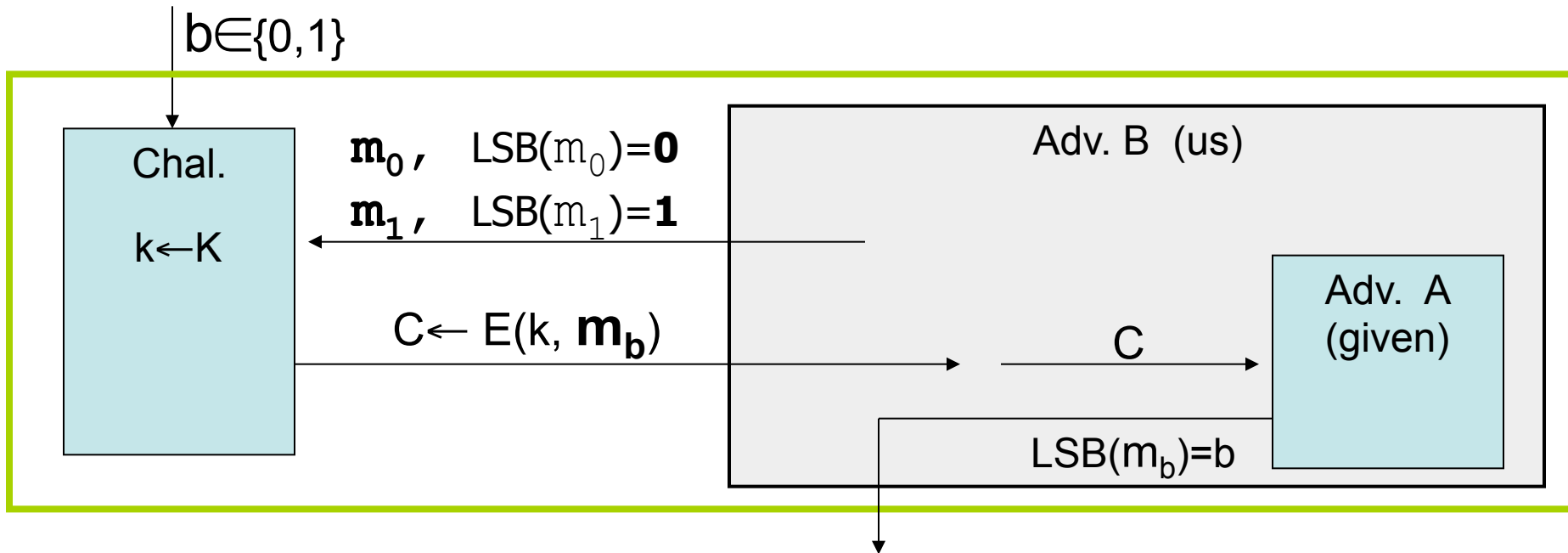

- Then  $SS \text{ Adv}[B, E] = 1 \Rightarrow E$  is not sem. sec.

# Note: ECB is not Sem. Sec.

- Electronic Code Book (ECB):
  - Not semantically secure for messages that contain more than one block.

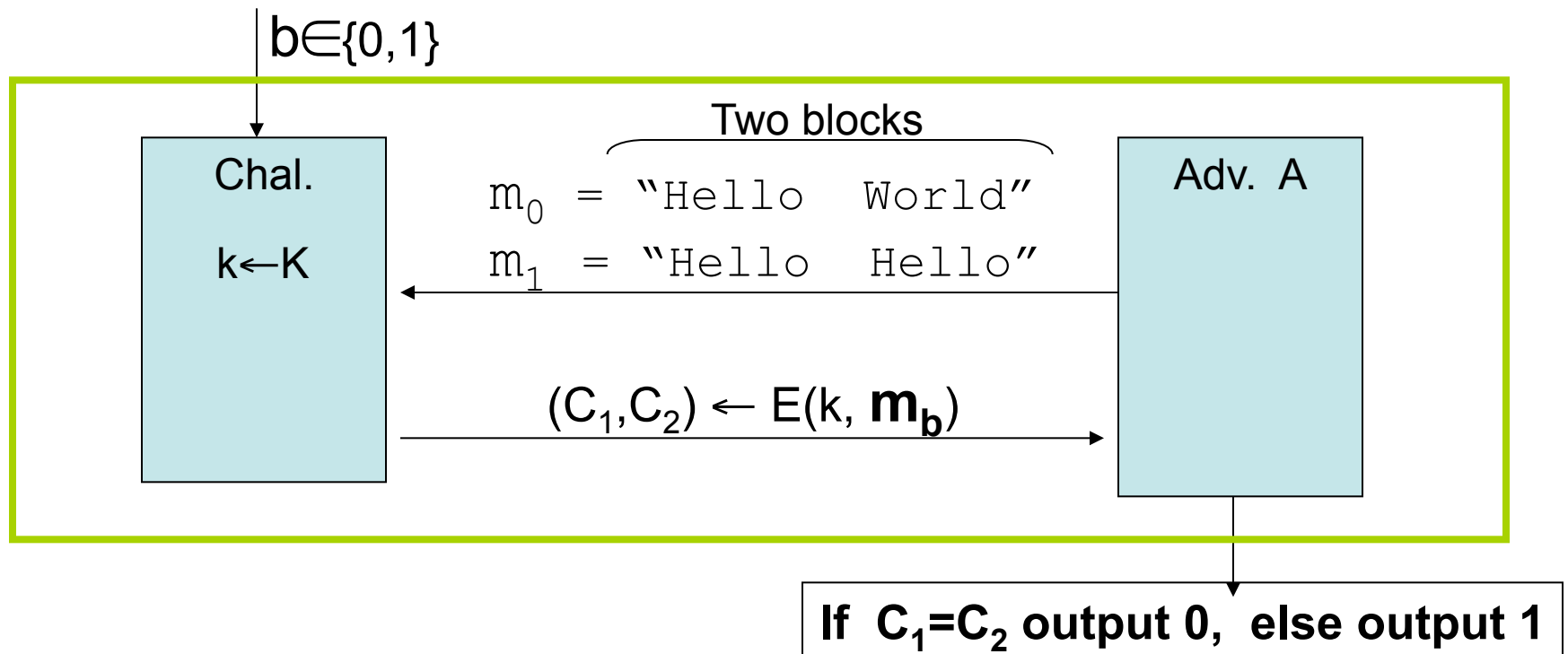

- Then  $SS \text{ Adv}[A, \text{ECB}] = 1$



# Secure Constructions

- Examples of sem. sec. systems:

1.  $SS \text{ Adv}[A, \text{OTP}] = 0$  for all  $A$

2. Deterministic counter mode from a PRF  $F$  :

- $E_{\text{DETCTR}}(k,m) =$

$$\begin{array}{cccc} m[0] & m[1] & \dots & m[L] \\ \oplus & & & \\ \mathbf{F(k,0)} & \mathbf{F(k,1)} & \dots & \mathbf{F(k,L)} \\ \hline c[0] & c[1] & \dots & c[L] \end{array}$$

- Stream cipher built from PRF (e.g. AES, 3DES)

# Det. counter-mode security

- Theorem: For any  $L > 0$ .

If  $F$  is a secure PRF over  $(K, X, X)$  then

$E_{\text{DETCTR}}$  is sem. sec. cipher over  $(K, X^L, X^L)$ .

In particular, for any adversary  $A$  attacking  $E_{\text{DETCTR}}$  there exists a PRF adversary  $B$  s.t.:

$$\text{SS Adv}[A, E_{\text{DETCTR}}] = 2 \cdot \text{PRF Adv}[B, F]$$

---

PRF Adv $[B, F]$  is negligible (since  $F$  is a secure PRF)

Hence, SS Adv $[A, E_{\text{DETCTR}}]$  must be negligible.

# Modes of Operation for Many-time Key

## Example applications:

1. File systems: Same AES key used to encrypt many files.
2. IPsec: Same AES key used to encrypt many packets.

# Semantic Security for many-time key (CPA security)

Cipher  $E = (E, D)$  defined over  $(K, M, C)$ .

For  $b=0,1$  define  $\text{EXP}(b)$  as:

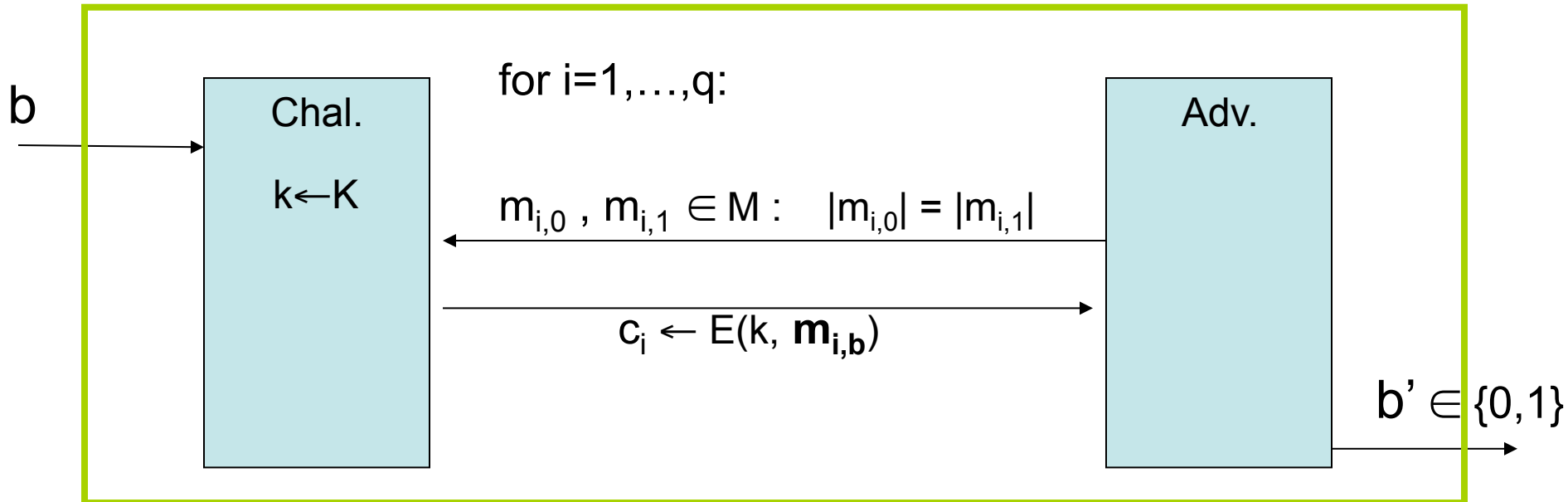

if adv. wants  $c = E(k, m)$  it queries with  $m_{j,0} = m_{j,1} = m$

Def:  $E$  is sem. sec. under CPA if for all "efficient"  $A$ :

$\text{Adv}_{\text{CPA}}[A, E] = \left| \Pr[\text{EXP}(0)=1] - \Pr[\text{EXP}(1)=1] \right|$   
is "negligible."

# Security for many-time key

- Fact: stream ciphers are insecure under CPA.
  - More generally: if  $E(k,m)$  always produces same ciphertext, then cipher is insecure under CPA.

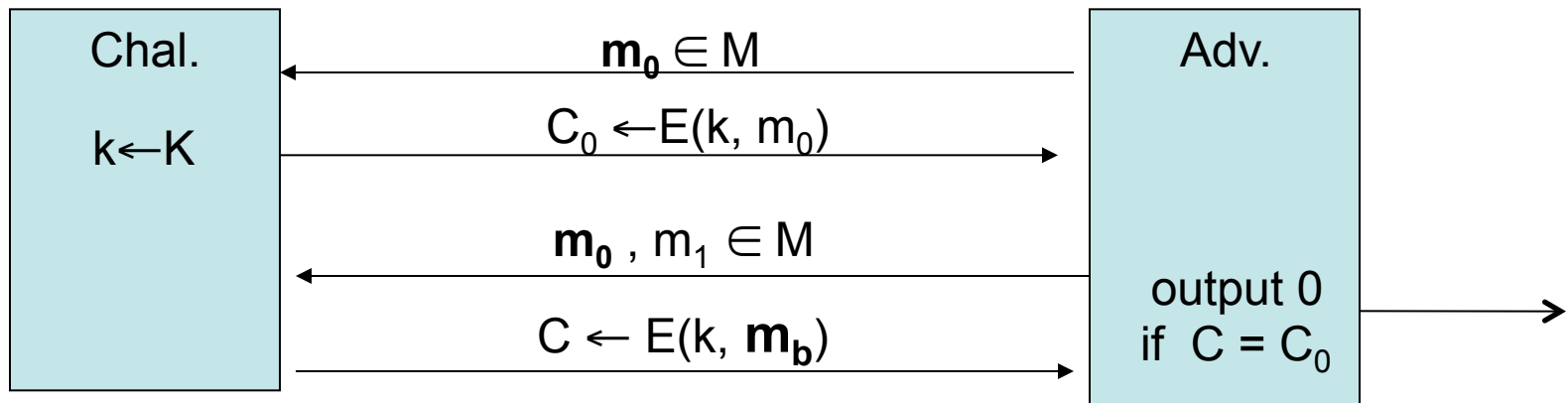

- If secret key is to be used multiple times  $\Rightarrow$   
given the same plaintext message twice,  
the encryption alg. must produce different outputs.

# Nonce-based Encryption

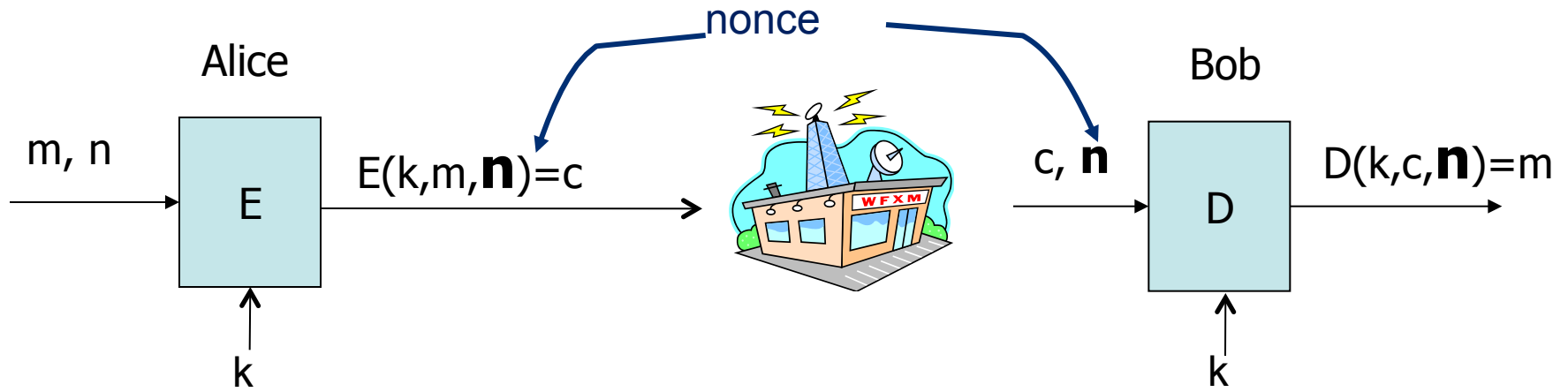

- nonce  $n$ : a value that changes from msg to msg  
( $k, n$ ) pair never used more than once
- method 1: encryptor picks a random nonce,  $n \leftarrow \mathcal{N}^c$
- method 2: nonce is a counter (e.g. packet counter)
  - used when encryptor keeps state from msg to msg
  - if decryptor has same state, need not send nonce with CT

# Construction 1: CBC with random nonce

- Cipher block chaining with a random IV (IV = nonce)

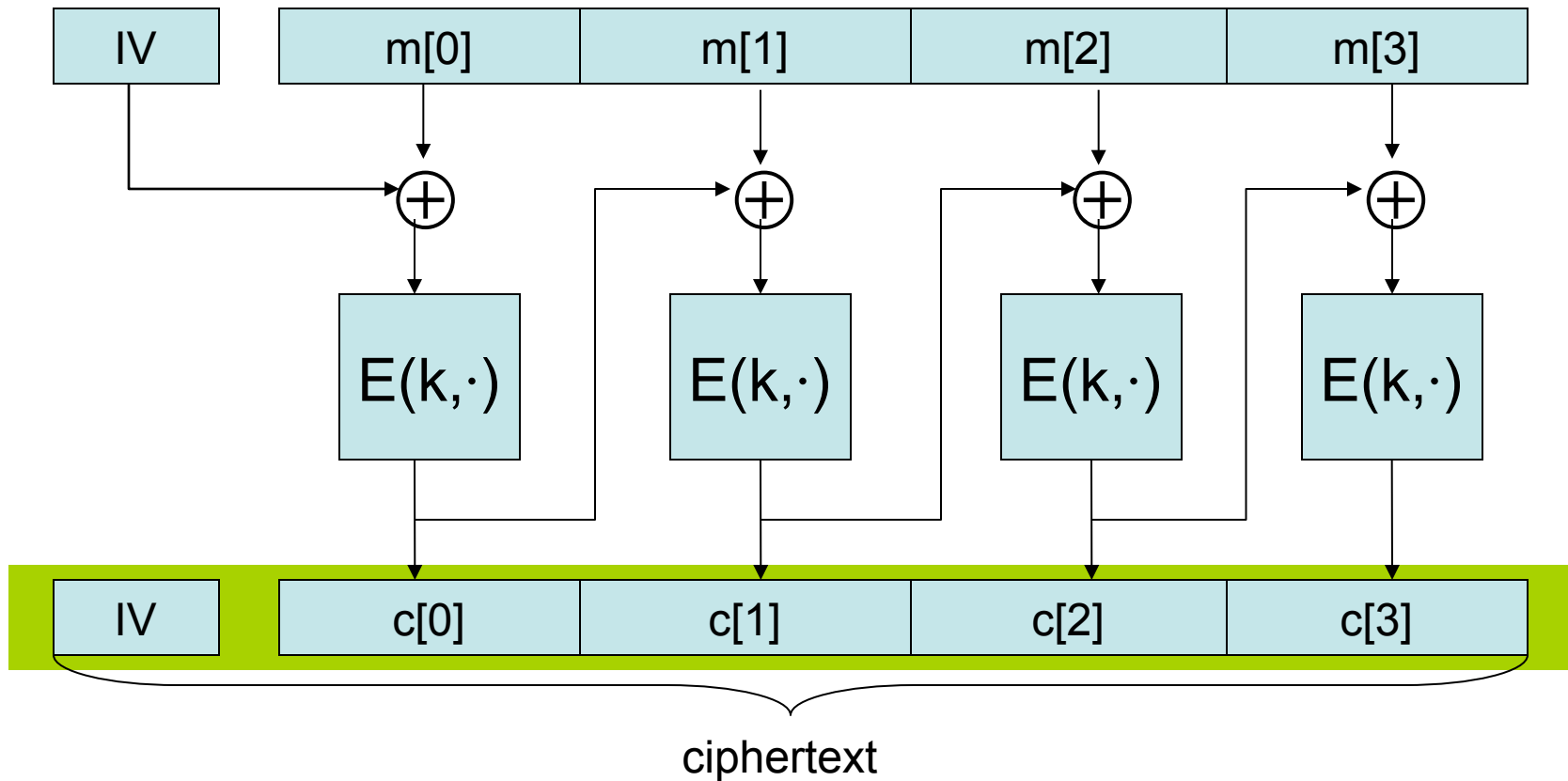

# CBC: CPA Analysis

- CBC Theorem: For any  $L > 0$ ,  
If  $E$  is a secure PRP over  $(K, X)$  then  
 $E_{\text{CBC}}$  is a sem. sec. under CPA over  $(K, X^L, X^{L+1})$ .

In particular, for a  $q$ -query adversary  $A$  attacking  $E_{\text{CBC}}$  there exists a PRP adversary  $B$  s.t.:

$$\text{SS}_{\text{CPA}} \text{Adv}[A, E_{\text{CBC}}] \leq 2 \cdot \text{PRP Adv}[B, E] + 2 q^2 L^2 / |X|$$

- Note: CBC is only secure as long as  $q^2 L^2 \ll |X|$



# Construction 1': CBC with **unique** nonce

- Cipher block chaining with unique IV (IV = nonce)

unique IV means: (key,IV) pair is used for only one message

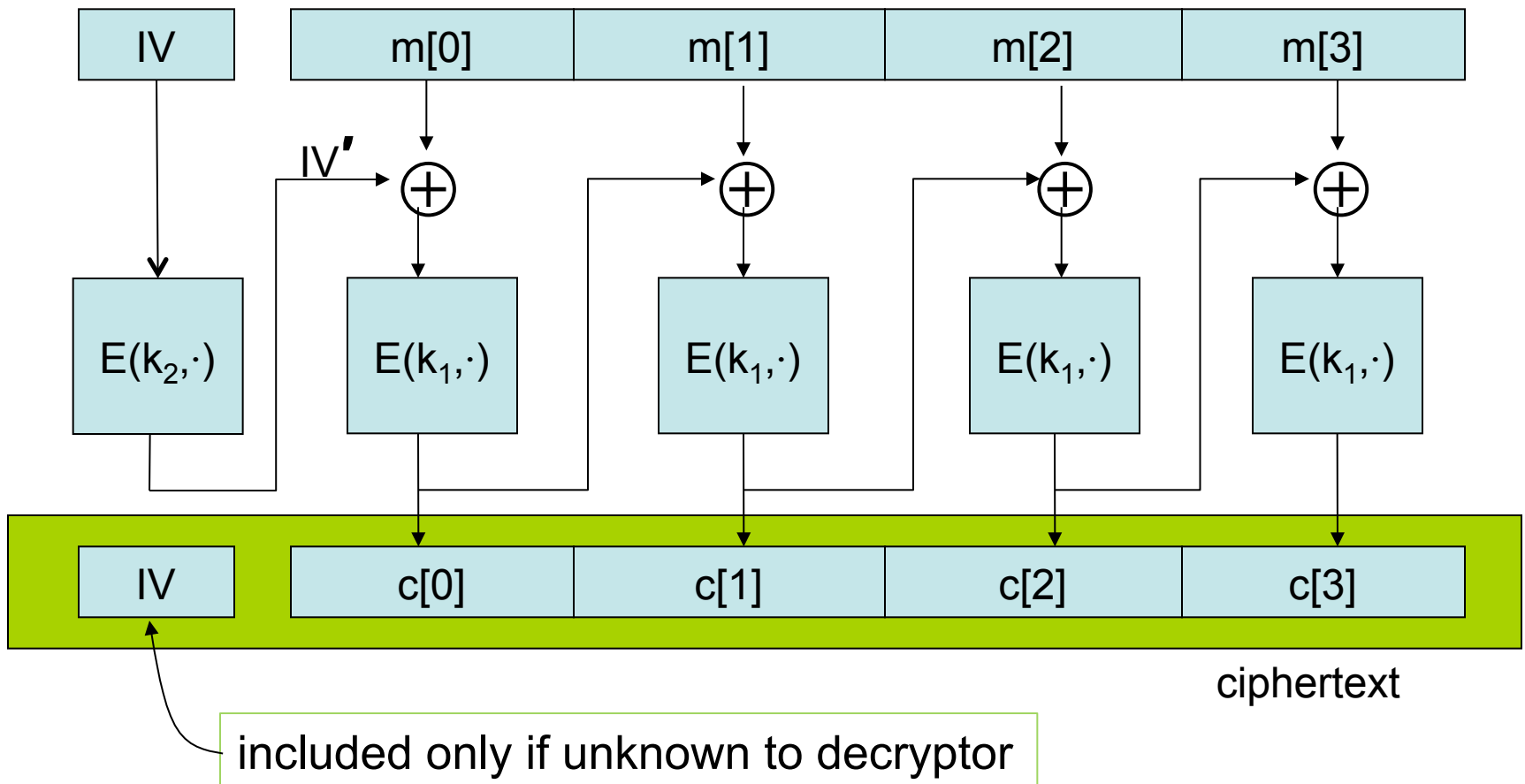

# A CBC technicality: padding

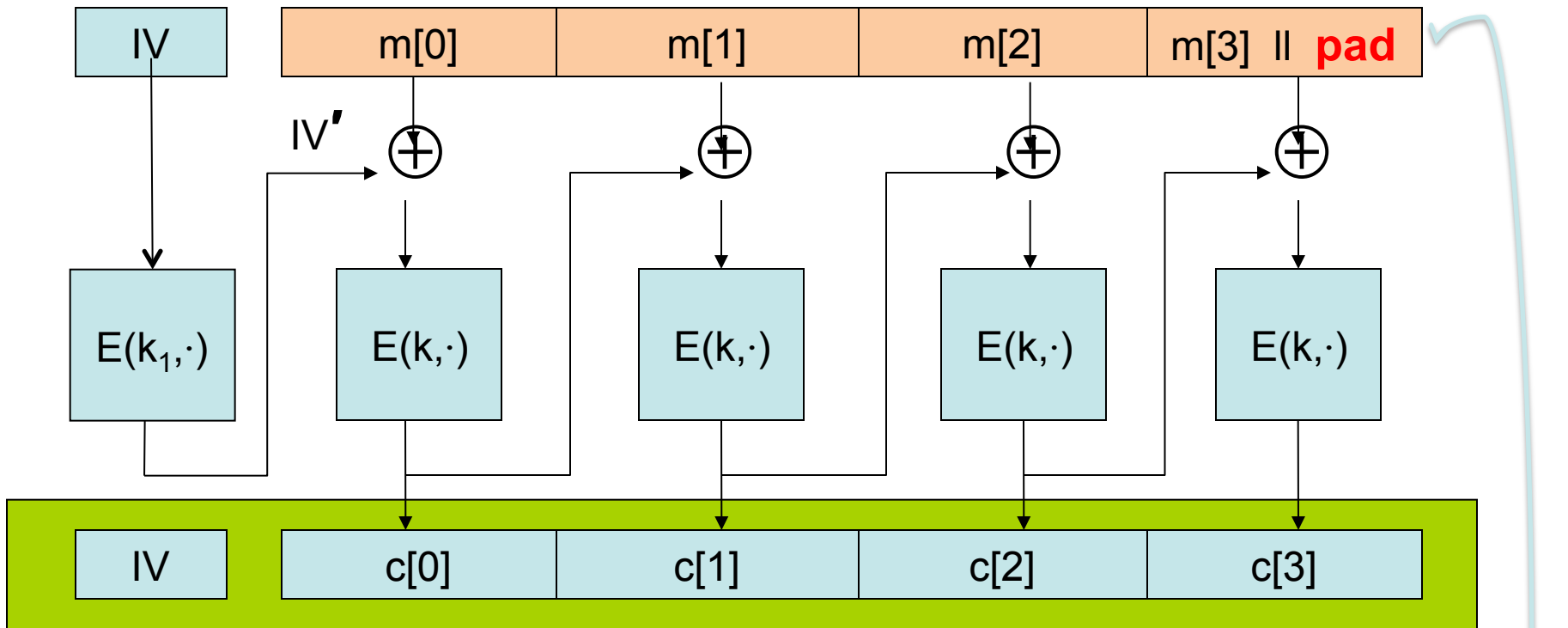

TLS: for  $n > 0$ ,  $n+1$  byte pad is 

n	n	n	...	n
---	---	---	-----	---

  
if no pad needed, add a dummy block

removed during decryption

# Construction 2: rand ctr-mode

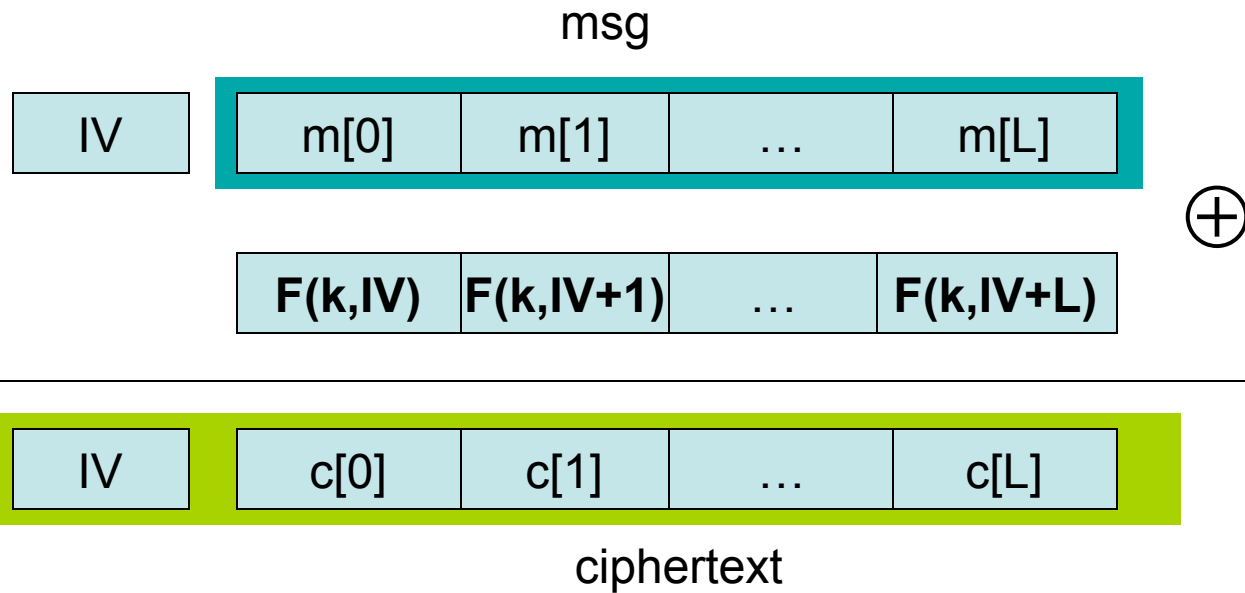

IV - chosen at random for every message

note: parallelizable (unlike CBC)

# Construction 2': nonce ctr-mode

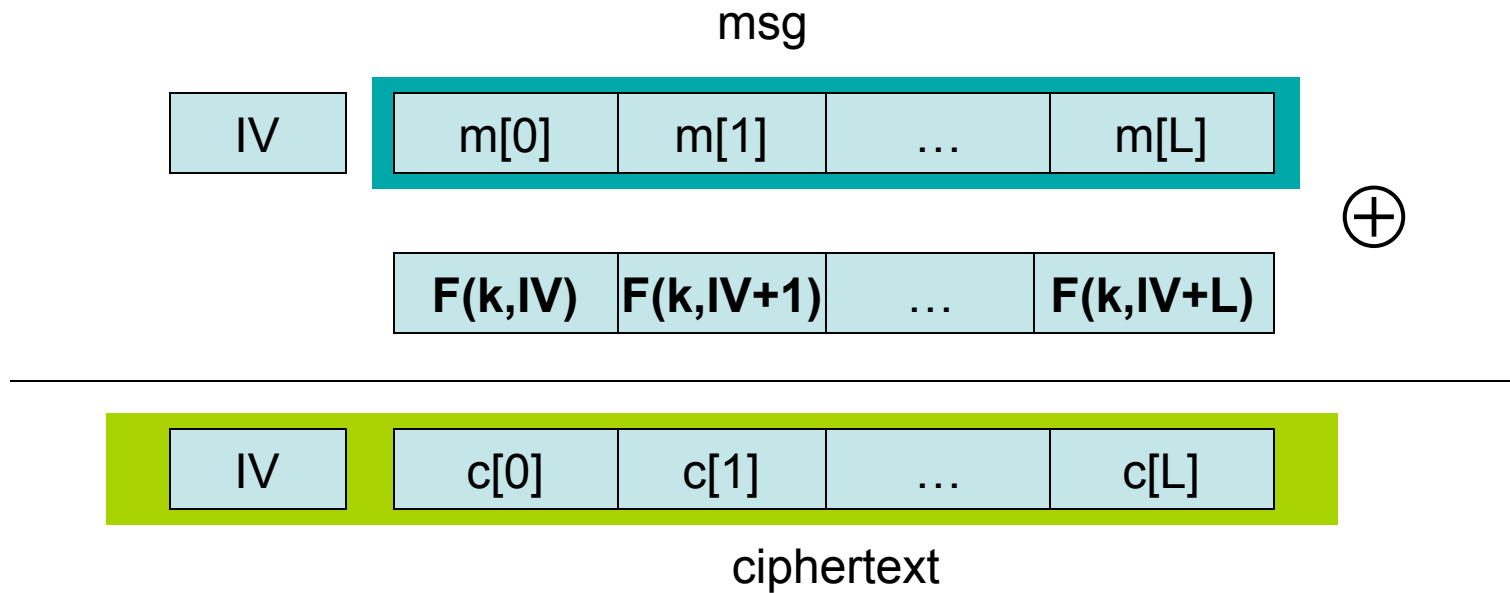

To ensure  $F(K, x)$  is never used more than once, choose IV as:

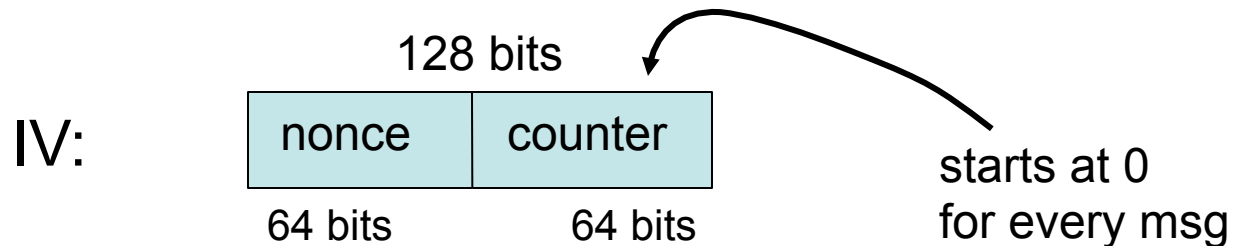

# rand ctr-mode: CPA analysis

- Randomized counter mode: random IV.

- Counter-mode Theorem: For any  $L > 0$ ,

If  $F$  is a secure PRF over  $(K, X, X)$  then

$E_{CTR}$  is a sem. sec. under CPA over  $(K, X^L, X^{L+1})$ .

In particular, for a  $q$ -query adversary  $A$  attacking  $E_{CTR}$  there exists a PRF adversary  $B$  s.t.:

$$SS_{CPA} \text{ Adv}[A, E_{CTR}] \leq 2 \cdot \text{PRF Adv}[B, F] + 2 q^2 L / |X|$$

- Note: ctr-mode only secure as long as  $q^2 L \ll |X|$

Better than CBC !

# Summary

- PRPs and PRFs: a useful abstraction of block ciphers.
- We examined two security notions:
  1. Semantic security against one-time CPA.
  2. Semantic security against many-time CPA.

Note: neither mode ensures data integrity.
- Stated security results summarized in the following table:

Power Goal	one-time key	Many-time key (CPA)	CPA and CT integrity
<b>Sem. Sec.</b>	stream-ciphers det. ctr-mode	rand CBC rand ctr-mode	later